

FXL800-70N (WITHOUT SOFTENER)
 400/50/3 + N + E 6.1kW BOOSTER 7.7kW TOTAL
 SWITCHABLE TO
 230/50/1 4.15kW BOOSTER 5.6kW TOTAL
 230/50/1 1.38kW BOOSTER 2.9kW TOTAL

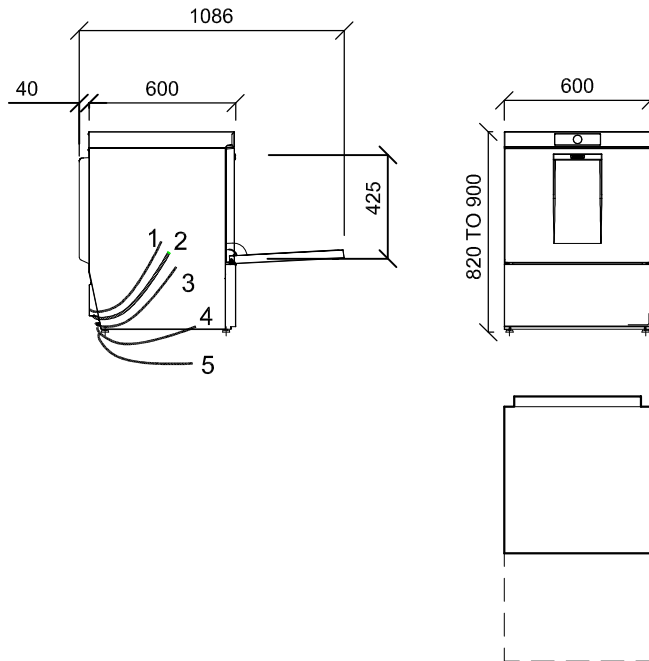

SERVICES SCHEDULE

5	Rinse Aid hose 2.5 metres flexible hose. Continual flow 0 to 0.4 litres/hour
4	Detergent hose 2.5 metres flexible hose. Continual flow 0 to 3.0 litres/hour
3	SUPPLIED WITH 2.0 METRES OF CABLE 400/50/3 + N + E 7.7kW 15.9AMPS Fuse: 16AMPS/PHASE 230/50/1 5.6kW 24.9AMPS FUSE 25AMPS 230/50/1 2.9kW 12.9AMPS FUSE 13AMPS
2	WATER 10-60°C MAX. 0.6 to 6 Bar pressure 60°C REQUIRED FOR MAXIMUM THROUGHPUT. Water supply pipework 22m.m. minimum Machine connection 2.0 metres flexible hose 12m.m. inside diameter with 3/4" B.S.P. female termination Machine supplied with Class `AA` air gap Recommended water hardness 2 to 8°C Clarke Initial tank fill 10.8 litres Rinse water usage 2.5 litres per cycle, maximum usage 100 litres per hour
1	Drain 28m.m. outside diameter 2.00 metres flexible hose connection to a 40m.m. trapped standpipe, maximum height 800m.m. from F.F.L. Peak flow rate 30 litres per minute
	Installation should comply with all National and Local codes of practice
	RIGHT TO MAKE NECESSARY CHANGES IS RESERVED

APPROXIMATE WEIGHT kg's:

	EMPTY	WITH WATER
FXL800	65	87



HEAT RADIATION
 WASHWARE 1.1kW MACHINE 0.3kW TOTAL 1.4kW

NOISE EMISSION 63dB (A) MEASURED AT 1 METRE FROM DOOR