

**GXHS-70N (WITH SOFTENER)**  
**400/50/3 + N + E 6.1kW BOOSTER 7.7kW TOTAL**  
**SWITCHABLE TO**  
**230/50/1 4.15kW BOOSTER 5.6kW TOTAL**  
**230/50/1 1.38kW BOOSTER 2.9kW TOTAL**

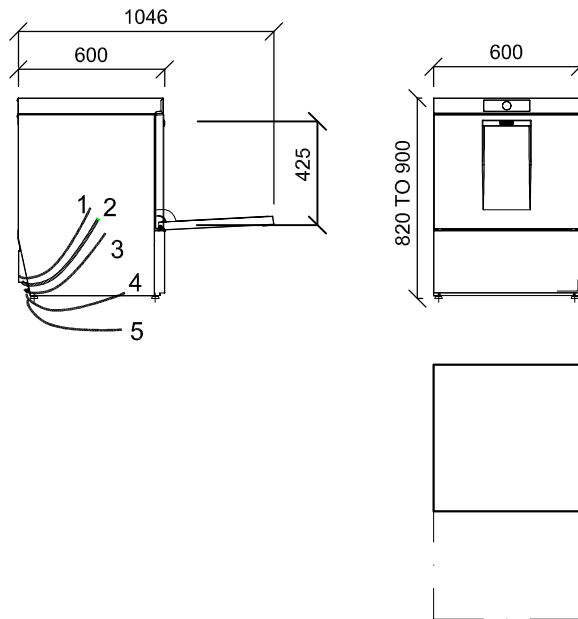

**SERVICES SCHEDULE**

|   |   |
|---|---|
| 5 | Rinse Aid hose 2.5 metres flexible hose. Continual flow 0 to 0.4 litres/hour  |
| 4 | Detergent hose 2.5 metres flexible hose. Continual flow 0 to 3.0 litres/hour  |
| 3 | SUPPLIED WITH 2.0 METRES OF CABLE<br>400/50/3 + N + E 7.7kW 15.9AMPS Fuse: 16AMPS/PHASE<br>230/50/1 5.6kW 24.9AMPS FUSE 25AMPS<br>230/50/1 2.9kW 12.9AMPS FUSE 13AMPS   |
| 2 | WATER 10-60°C MAX. 0.6 to 6 Bar pressure<br>60°C REQUIRED FOR MAXIMUM THROUGHPUT.<br>Water supply pipework 22m.m. minimum<br>Machine connection 2.0 metres flexible hose 12m.m. inside diameter with 3/4" B.S.P. female termination<br>Machine supplied with Class `AA` air gap<br><br>Initial tank fill 10.8 litres<br>Rinse water usage 2.5 litres per cycle, maximum usage 150 litres per hour |
| 1 | Drain<br>28m.m. outside diameter 2.00 metres flexible hose connection to a 40m.m. trapped standpipe, maximum height 800m.m. from F.F.L. Peak flow rate 30 litres per minute   |
|   | Installation should comply with all National and Local codes of practice  |
|   | RIGHT TO MAKE NECESSARY CHANGES IS RESERVED   |

APPROXIMATE WEIGHT kg's:

|          |       |            |
|----------|-------|------------|
|          | EMPTY | WITH WATER |
| GXHS-70N | 65    | 87         |



HEAT RADIATION  
WASHWARE 1.1kW MACHINE 0.3kW TOTAL 1.4kW

NOISE EMISSION 63dB (A) MEASURED AT 1 METRE FROM DOOR