

UX-11 30 RACKS/HOUR WITH 9.0kW RINSE BOOSTER HEATING

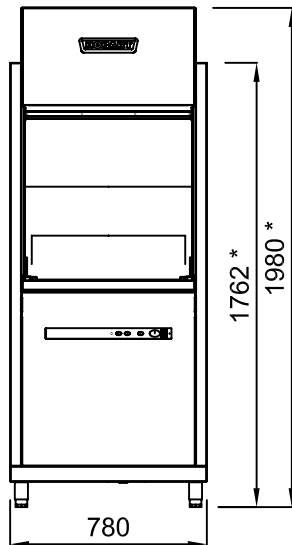

THIS MACHINE CAN GO AGAINST A WALL
i.e. NO CLEARANCE REQUIRED AT THE REAR
OF THE MACHINE

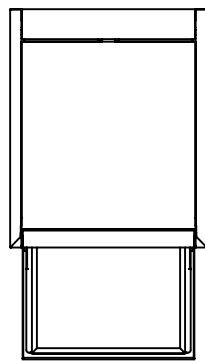
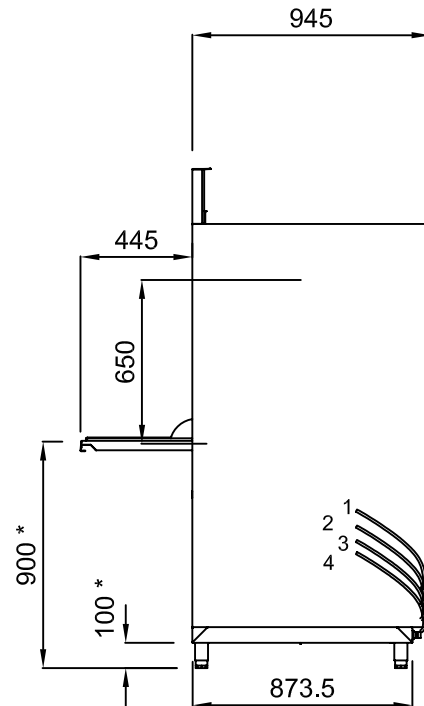

DIMENSIONS MARKED
THUS * INDICATE
± 15

SERVICES SCHEDULE

| | |
|---|--|
| 4 | Rinse agent hose 2.5 metres |
| 3 | Electrical connection 400/50/3 + N + E 12.1kW 19.0AMPS Fuse: 20AMPS/PHASE Cable: 4 x 4.0m.m.2 + E |
| 2 | Water supply 60°C - 0.6 to 6 BAR pressure Water supply pipe 22m.m. (minimum) Machine connection 1.5 metres flexible hose 12m.m. inside diameter with 3/4" B.S.P. female termination Machine supplied with Class `AA` Air Gap Recommended maximum water hardness 2 to 8° Clark Initial tank fill 64 litres Rinse water usage 5.5 litres per cycle maximum usage 165 litres per hour |
| 1 | Drain 24m.m. inside diameter 28m.m. outside diameter, 2.0 metres Flexible Hose Connection to a 40m.m. Trapped Standpipe 860m.m. A.F.F.L. Flow 30 litres/min at 0.45 BAR |
| | Installation should comply with all National and Local codes of practice |
| | RIGHT TO MAKE NECESSARY CHANGES IS RESERVED |

WEIGHT kg's:



| | | |
|----|-------|------------|
| | EMPTY | WITH WATER |
| UX | 190 | 254 |