

# HOOD TYPE / PASS THROUGH DISHWASHERS AMX SERIES



HOBART UK, SOUTHGATE WAY, ORTON SOUTHGATE, PETERBOROUGH, PE2 6GN  
TELEPHONE 0844 888 7777  
www.hobartuk.com

## Hood Type Dishwasher

AMX-16

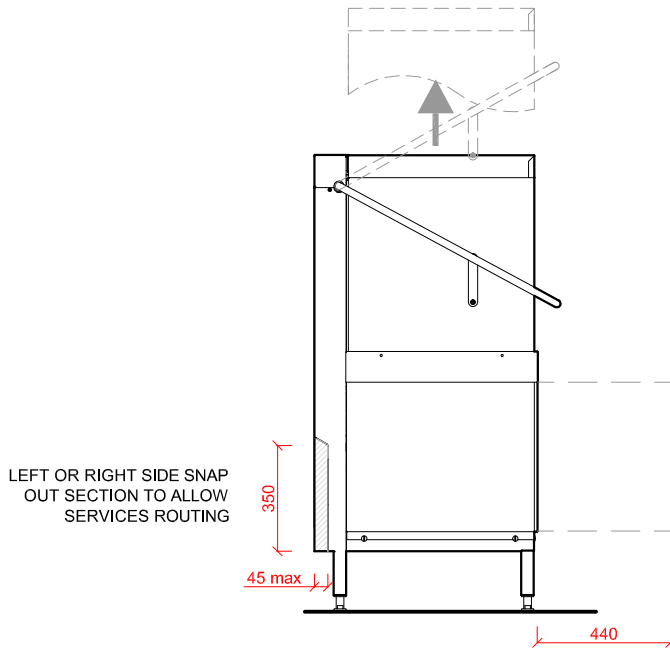

ESSENTIAL FOR SERVICE ACCESS

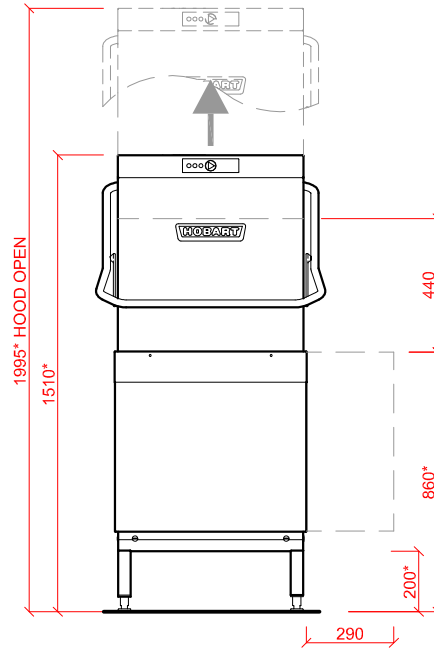

ESSENTIAL FOR SERVICE ACCESS

### Example Corner Configuration

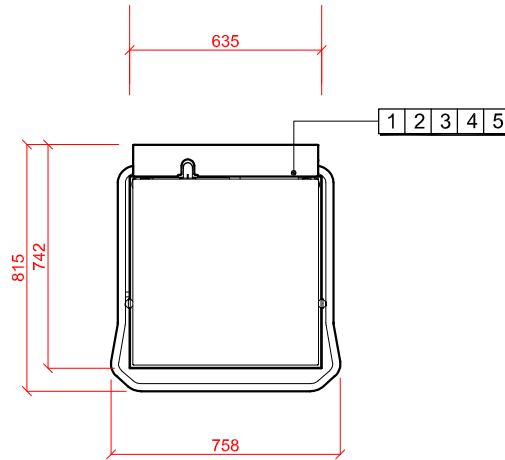
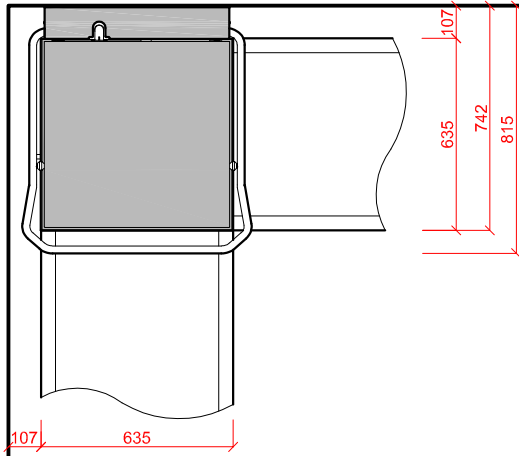

<p><b>1</b> Water</p> <p>22m.m. CONNECTION VIA 2 METRE FLEXIBLE HOSE, FEMALE TERMINATION.</p> <p>WATER SUPPLY 60°C (2° TO 8° CLARK MAX) @ 0.5 TO 10 BAR MAX.</p> <p>INITIAL TANK FILL 21 LITRES.</p> <p>RINSE WATER USAGE 2.5 LITRES PER CYCLE. MAX USAGE 150 LITRES PER HOUR.</p> <p>OUR MACHINES ARE SUPPLIED WITH CLASS 'AA' AIR GAP AS STANDARD.</p>	<p><b>2</b> Drain</p> <p>DRAIN - 2 METRE FLEXIBLE HOSE TO A 40 m.m. TRAPPED STANDPIPE 500m.m. A.F.F.L.</p> <p>FLOW RATE 30 LITRES PER MINUTE.</p> <p><b>4</b> <b>5</b> Other Services</p> <p>RINSE AGENT HOSE - 2.0 METRE FLEXIBLE.</p> <p>DETERGENT HOSE - 2.0 METRE FLEXIBLE.</p>	<p><b>3</b> Electric Loading</p> <p>7.0kW 400/50/3 + N + E FUSED AT 16AMPS / PHASE. <b>CONFIGURABLE TO</b> 4.9kW 230/50/1 FUSED AT 25AMPS</p> <p>MACHINE SUPPLIED WITH 2.5 METRES OF CABLE.</p> <p>Notes</p> <p>APPROX WEIGHTS: EMPTY: 105kg's WITH WATER: 137kg's</p> <p>HEIGHTS MARKED * REPRESENT ±20m.m.</p> <p>MIN DISTANCE FROM WALL TO INSIDE OF TABLING BOXED EDGE 154.5m.m.</p>
--	---	--