

# HOOD TYPE / PASS THROUGH DISHWASHERS AUXX SERIES



HOBART UK, SOUTHGATE WAY, ORTON SOUTHGATE, PETERBOROUGH, PE2 6GN  
TELEPHONE 0844 888 7777  
www.hobartuk.com

## Hood Type Dishwasher with Integral Softener

AUXXS-31

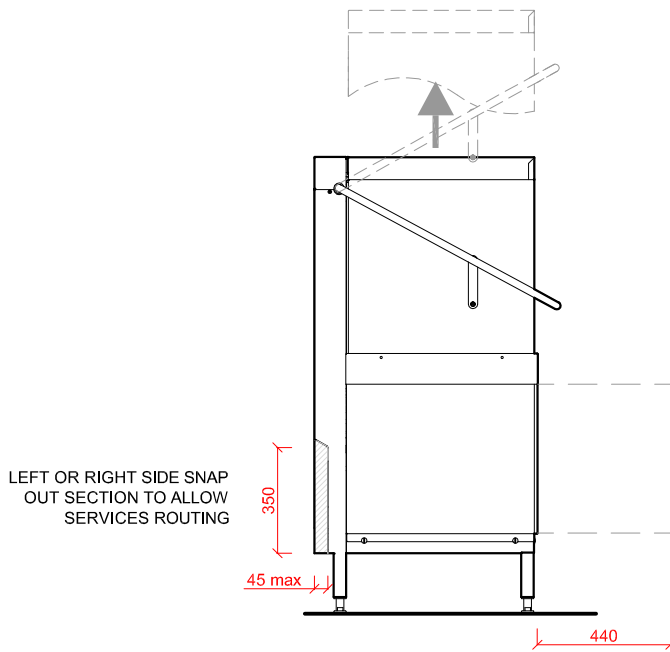

LEFT OR RIGHT SIDE SNAP  
OUT SECTION TO ALLOW  
SERVICES ROUTING

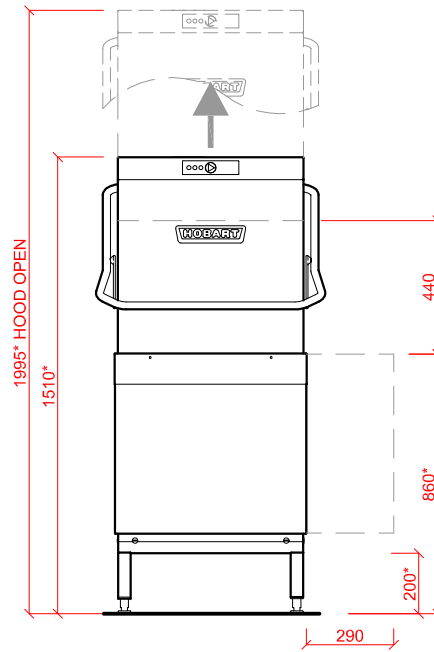

ESSENTIAL FOR  
SERVICE ACCESS

ESSENTIAL FOR  
SERVICE ACCESS

### Example Corner Configuration

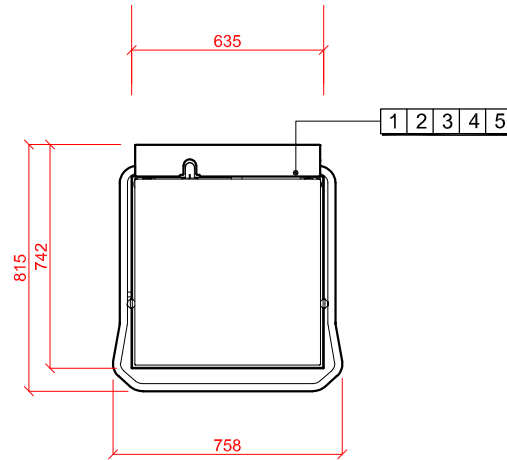
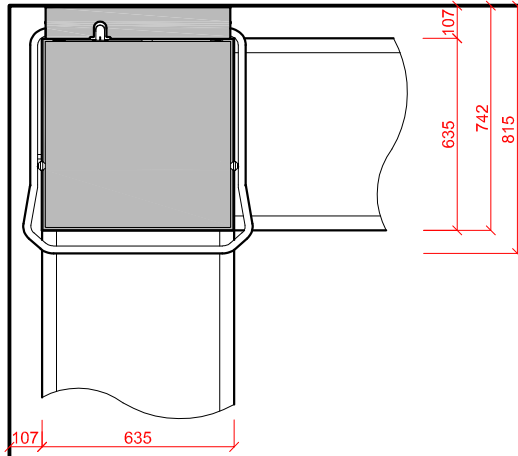

<p><b>1</b> Water</p> <p>22m.m. CONNECTION VIA 2 METRE FLEXIBLE HOSE, FEMALE TERMINATION.</p> <p>COLD WATER SUPPLY 10°C @ 0.5 TO 10 BAR MAX.</p> <p><b>OR</b></p> <p>HOT WATER SUPPLY 60°C @ 0.5 TO 10 BAR MAX.</p> <p>INITIAL TANK FILL 40 LITRES.</p> <p>RINSE WATER USAGE 2.5 LITRES PER CYCLE. MAX USAGE 175 LITRES PER HOUR.</p> <p>OUR MACHINES ARE SUPPLIED WITH CLASS 'AA' AIR GAP AS STANDARD.</p>	<p><b>2</b> Drain</p> <p>DRAIN - 2 METRE FLEXIBLE HOSE TO A 40 m.m. TRAPPED STANDPIPE 500m.m. A.F.F.L.</p> <p>FLOW RATE 30 LITRES PER MINUTE.</p> <p><b>4 5</b> Other Services</p> <p>RINSE AGENT HOSE - 2.0 METRE FLEXIBLE.</p> <p>DETERGENT HOSE - 2.0 METRE FLEXIBLE.</p>	<p><b>3</b> Electric Loading</p> <p>17.1kW 400/50/3 + N + E <b>FOR COLD FEED</b> FUSED AT 35AMPS / PHASE.</p> <p><b>CONFIGURABLE TO</b></p> <p>10.9kW 400/50/3 + N + E <b>FOR HOT FEED</b> FUSED AT 25AMPS / PHASE.</p> <p>MACHINE SUPPLIED WITH 2.5 METRES OF CABLE.</p> <p><b>Notes</b></p> <p>APPROX WEIGHTS: EMPTY: 138kg's WITH WATER: 189kg's</p> <p>HEIGHTS MARKED * REPRESENT ±20m.m.</p> <p>MIN DISTANCE FROM WALL TO INSIDE OF TABLING BOXED EDGE 154.5m.m.</p>
---	--	---