

# UNDERCOUNTER DISHWASHERS FX SERIES



HOBART UK, SOUTHGATE WAY, ORTON SOUTHGATE, PETERBOROUGH, PE2 6GN  
TELEPHONE 0844 888 7777 [www.hobartuk.com](http://www.hobartuk.com)

## Undercounter Dishwasher

FXL800-70N

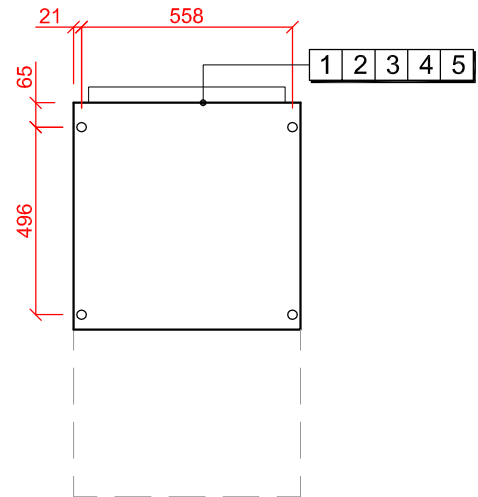
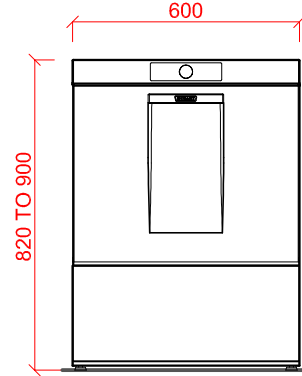
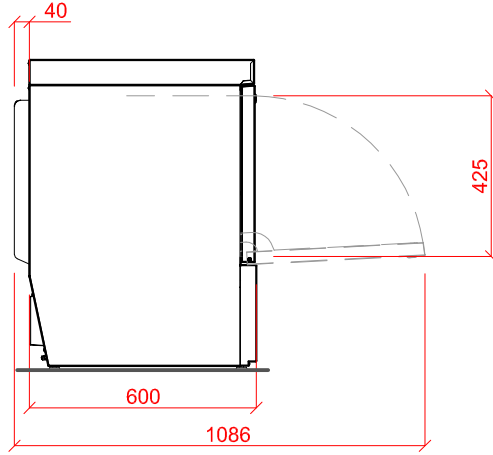

<p><b>1</b> Water</p> <p>22m.m. CONNECTION VIA 2 METRE FLEXIBLE HOSE, FEMALE TERMINATION.</p> <p>WATER SUPPLY 10 TO 60°C (2° TO 8° CLARK MAX) @ 0.6 TO 6.0 BAR MAX. INITIAL TANK FILL 10.8 LITRES.</p> <p>RINSE WATER USAGE 2.5 LITRES PER CYCLE. MAX USAGE 100 LITRES PER HOUR.</p> <p>OUR MACHINES ARE SUPPLIED WITH CLASS 'AA' AIR GAP AS STANDARD.</p>	<p><b>2</b> Drain</p> <p>DRAIN - 2 METRE FLEXIBLE HOSE TO A 40 m.m. TRAPPED STANDPIPE 800m.m. MAX A.F.F.L.</p> <p>FLOW RATE 30 LITRES PER MINUTE.</p> <p><b>4 5</b> Other Services</p> <p>RINSE AGENT HOSE - 2.5 METRE FLEXIBLE. DETERGENT HOSE - 2.5 METRE FLEXIBLE.</p>	<p><b>3</b> Electric Loading</p> <p>7.7kW 400/50/3 + N + E FUSED AT 16AMPS / PHASE. <b>CONFIGURABLE TO</b> 5.6kW 230/50/1 FUSED AT 25AMPS OR 2.9kW 230/50/1 FUSED AT 13AMPS MACHINE SUPPLIED WITH 2.0 METRES OF CABLE.</p> <p>Notes</p> <p>APPROX WEIGHTS: EMPTY: 65kg's WITH WATER: 87kg's</p>
--	---	---