

COMBINATION OVENS  
CHEFMATE SERIES



Hobart Cooking Solutions

Southgate Way  
Orton Southgate  
Peterborough  
PE2 6GN

Telephone - 0844 225 1999  
www.hobartuk.com/cooking

Chefmate Full Touch Gas 6 Grid Combination Oven

HCSCMFG6

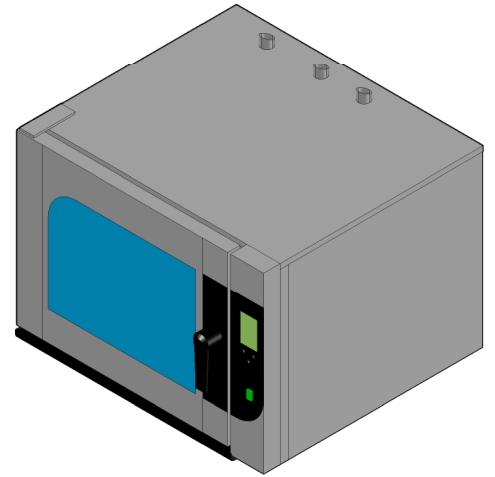
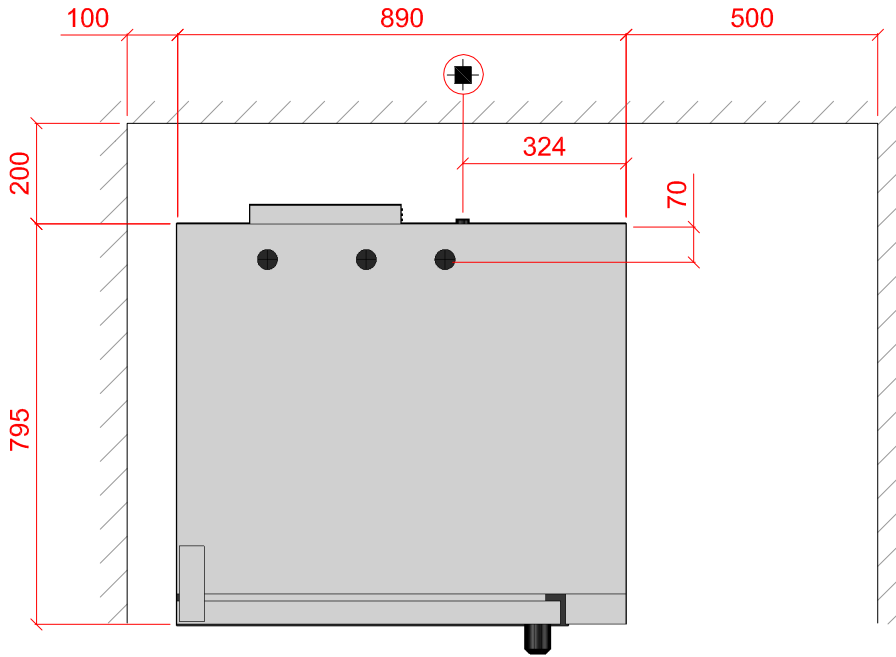

Plan View Showing Suggested Install/Service access Clearances

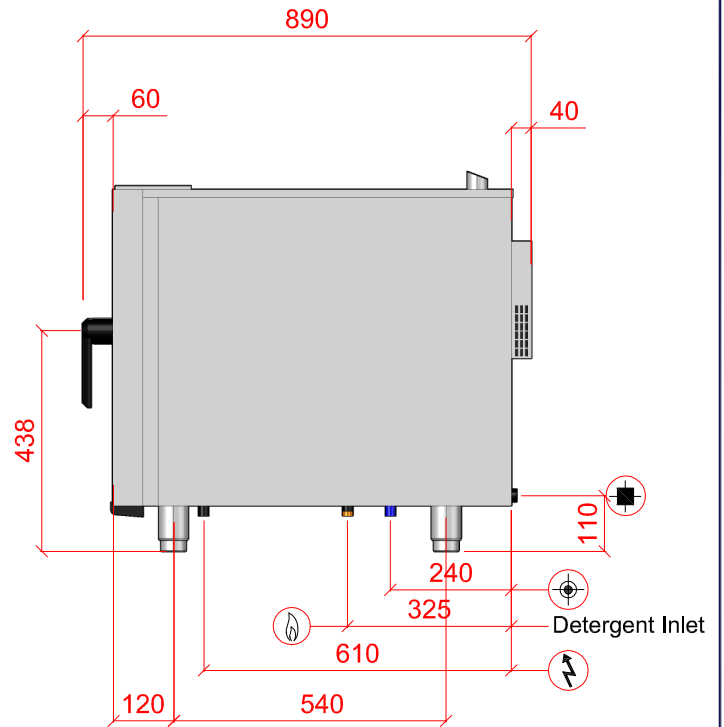
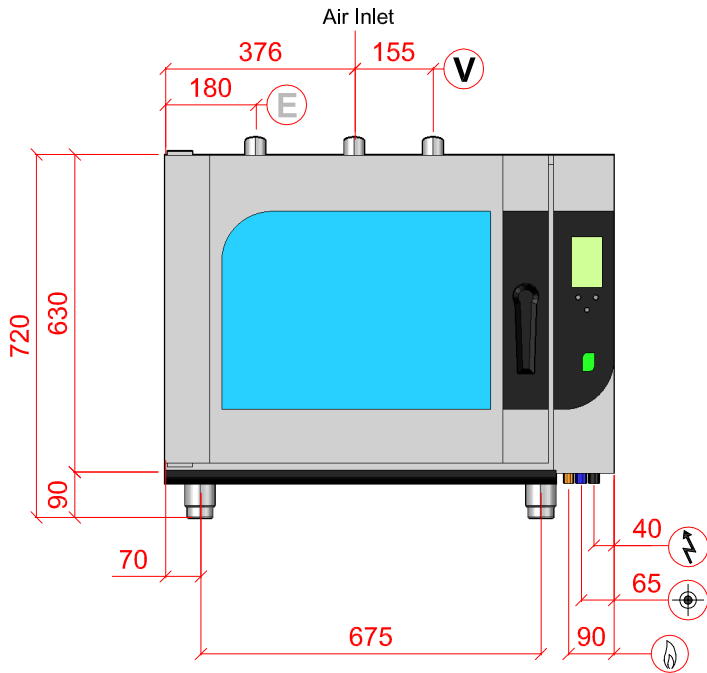

Temperature Cooking Range - 40 to 250°C

Water	Drain	Electric Loading	Gas Loading	Vent Outlet
3/4" B.S.P. POTABLE WATER, 2.0 TO 4.0 BAR MAX PRESSURE. MAX TEMP: 30°C (2 TO 5° CLARK MAX) <b>5°e, 70ppm - MAX WATER HARDNESS PERMITTED.</b> <b>WATER QUALITY: MAXIMUM CONCENTRATION OF CHLORIDE Cl:100mg/l AND CHLORINE Cl:0.2mg/l</b>	1" DRAIN CONDENSATE TEMPERATURE APPROX 98°C	0.7kW 230/50/1 FUSE AT 13 AMP	12.5kW Connection 3/4" M	Ø40mm Recommended Extraction Flow 390m3/hour
<b>SPECIAL NOTE: DO NOT INSTALL UNIT CLOSE TO HOT APPLIANCES ON CONTROL PANEL SIDE UNIT SHOULD BE LOCATED UNDER A VENTILATION CANOPY. RECOMMENDED TO BE USED WITH A WATER TREATMENT SYSTEM.</b>				
WEIGHT 140kg net		RIGHT TO MAKE NECESSARY CHANGES IS RESERVED		

GAS CONNECTION 20mbar 
 ELECTRICAL CONNECTION 
 WATER CONNECTION 
 DRAIN 
 VENT OUTLET 
 EXHAUST BURNT GAS

**SPECIAL NOTE: INSTALLATION MUST COMPLY WITH CURRENT GAS SAFETY REGULATIONS AND BS 6173**

**PLOT SCALE: 1:15**