



The benchmark for quality and innovation



Cookers

High Speed Steam Cookers



High Speed Steam Cookers For The Professional Caterer

Looking for fantastic food quality, cooked in minutes and with the minimum of energy consumption.

The Hobart High Speed Steam Cooker uses a patented form of leading edge technology and offers a unique accelerated cooking technique; cooking fish, eggs, meat and rice in minutes and vegetables in seconds.



Model 205 G

- 12 portions of Supreme of Salmon in 1 minute
- 20 portions of tender stem broccoli in 30 seconds
- 10 portions of poached Chicken Supreme in 6 minutes

Model 305 G

- 42 portions of Supreme of Salmon in 1 minute
- 66 portions of tender stem Broccoli in 30 seconds
- 36 portions of poached Supreme of Chicken in 6 minutes



Model 205 G



Model 305 G

The Ultimate Cooking Experience

Consistent high quality food results are attained using high pressure dry latent heat. Fresh food is dry steam cooked on demand, retaining all the vitamins, minerals presentation colour and vital health giving properties.

- Ultimate Portion Control = No food waste
- Cooking to Order = A La Carte
- Volume Cooking = Banqueting and Central Production
- Poaching
- Boiling
- Braising
- Steaming
- Sous Vide
- Rechauffe

Features

- Full (1bar) Pressure
- Half (0.5 bar) Pressure
- Temperature Programmable on Atmospheric mode
- Cylindrical cooking chamber for even distribution of steam
- Boiler Pressure Dial
- Automatic Electrical fault diagnosis

Health and Safety

- Unique door mechanism seals from within - prevents unintentional opening during 'pressure' cooking cycle
- Automatic pressure safety override valve
- Free full on site staff training

Energy and the Environment

- Thermal efficient boiler and chamber insulation
- Integral drain condense box - automatically condenses the venting steam at end of the cook cycle to avoid special drain materials and making the working environment a cool and pleasant one
- WRAS approved - incorporates approved type A air gap
- Cooks five times faster than conventional methods
- Energy used to cook 1kg of Rice = 0.5 Litres of water and 0.34kw

User Friendly and Tactile

- Simple touch pad operation
- Ready to Cook in 5 minutes
- Simple Clean Design
- Spinning timer wheel
- Large LED display
- Single touch button automatic drain and boiler fill
- Audible and visual end of cook alarm
- Easy wipe clean interior and exterior
- The cook time remains constant regardless of same food quantity



Simple control settings for, half bar, one bar pressure and atmospheric temperature programme.



All stainless steel cooking compartment, circular, for even heat distribution and ease of cleaning.



Large capacity. The 305G takes three gastronorm 1/1 pans.

Technical Data





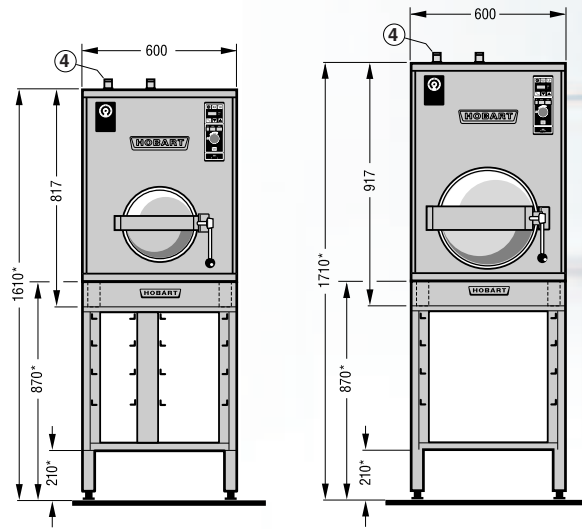

The benchmark for quality and innovation



Model	205 G	305 G
Portions per hour	400	650
Gastronorm pans	1/2 GN - 138 mm	1/1 GN - 200 mm
① Soft water connection	R 3/4"	R 3/4"
② Drain connection	R 1"	R 1"
③ Conduit size	PG 29	PG 29
Power supply	400/50/3N	400/50/3N
Electric rating	18.2 kW	27.2 kW
Fuse at	3 x 35 A	3 x 50 A
④ Internal vent pipe	Ø 35 mm	Ø 35 mm
⑤ Water supply	R 3/4"	R 3/4"
⑥ Power cable inlet	M 8	M 8
Dimension W x D x H	600 x 700 x 835	600 x 700 x 835

Saving Energy and Time

		Time (at 1 bar)	Power Used (kW per hour)	Water Usage (litres)
	8.0 kg Potatoes (quarters)	8 mins	0.5	0.5
	2.0 kg Carrots (sliced)	40 secs	0.15	0.3
	2.0 kg Cauliflower	45 secs	0.15	0.4
	5.0 kg Beans (frozen)	30 secs	0.25	0.8
	3.0 kg White cabbage	25 secs	0.2	0.4
	0.8 kg Vegetables julienne	15 secs	0.1	0.2
	2.0 kg Broccoli	40 secs	0.2	0.4
	4.0 kg Mixed vegetables (frozen)	30 secs	0.25	0.8
	3.0 kg Rice	7 mins	0.6	0.7
	30.0 kg Eggs (soft)	3-4 mins	0.3	0.5
	2.5 kg Salmon (tranche)	1-1.5 mins	0.3	0.2
	3.0 kg Haddock	1.5-2 mins	0.2	0.2
	4.0 kg Cod	1-2 mins	0.3	0.2



The benchmark for quality and innovation

Operation

Operates on zero, half, one bar pressure and is temperature programmable.

Ease of operation

Same time setting for 2oz or 30lb of product.

Quick start up

Simply push one button and the machine automatically gets itself ready in approximately 5 minutes.

Quick cooking times

Most vegetables cook in 1 to 3 minutes. Simply cook what you need when you need it – the ultimate in portion control.

Automatic Defrost

Same time setting for fresh, frozen or partially thawed product.

Four models

One to suit every size of operation from a 50 seat à la Carte restaurant to a 600 bed hospital.

Free on site training

Our qualified chefs will train your staff to ensure your customers get the best possible results.

Energy efficient

Insulated boiler and cooking chamber. Minimal power usage when on stand by.

Safety

Door cannot be opened when under pressure and is easy and quick to use.



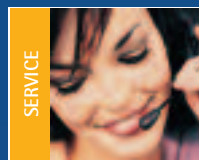

The benchmark for quality and innovation

0844 888 7777

Hobart UK, 51 The Bourne, Southgate, London N14 6RT. Fax No. 020 8886 0450
www.hobartuk.com