



The benchmark for quality and innovation



Dishwashers

Undercounter Warewashing Machines

Redefining the Industry Standard for Dishwashing

Introducing the technologically advanced FX and FXP Undercounter Dishwashers featuring the revolutionary INTENSIV wash system. The unique pre-wash, wash and rinse is standard on all models.

FXP machines also feature Hobart's unique VAPO-RINSE energy saving technology plus the INTENSIV4 system which incorporates an active drying cycle.

FX and FXP take dishwashing technology to a new dimension, light years ahead of any other undercounter machine on the market.

FX400

- Up to 20 racks per hour
- INTENSIV wash system
- In-built softener option

FX800

- Up to 40 racks per hour
- INTENSIV wash system
- In-built softener option

FXL800

- Up to 40 racks per hour
- Oversized wash chamber
- INTENSIV wash system
- In-built softener option

FXP

- Up to 40 racks per hour
- VAPO-RINSE economy rinsing
- INTENSIV4 wash system
- Hygiene cycle
- In-built softener option

Further Information

This brochure aims to provide you with everything you need to know to assist your purchasing decision, including technical specifications for the FX/FXP Series.

If you are left with any queries or wish to see a Hobart representative, don't hesitate to call the Hobart Customer Services team – you'll find contact details on the back of the brochure.



FX400/FX800



FXL800



FXP

Ease of Operation



The benchmark for quality and innovation

Easy to use

A dishwasher should be easy to use and customers tell us that having simple, understandable controls is of key importance - FX and FXP deliver on both counts by offering:

SMARTRONIC

- Single button activation for filling, cycle start and draining
- Colour coded sequence gives clear indication of machine status
- Additional functions eg. cycle selection and temperature indication can be accessed as required
- Less risk of incorrect operation and misuse

FXP - Cycle status indicator

- FXP models have additional indication to show the progress of each cycle plus the extra benefit of illuminated machine status within the door handle

Easy to clean

- Rounded corners and minimal components eliminates dirt traps
- Prior to shutdown an automatic flushing drain cycle rinses the machine
- Pump intake protection prevents ingress of foreign objects

FXP - Hygiene programme

- Selectable cycle ensuring thorough machine hygiene standards are maintained
- Using Hobart specially formulated **INTENSIV** tablets removes starch, tannin and lime deposits from the wash chamber, wash systems and strainers



GREEN - READY/STANDBY



BLUE - WASHING



CYCLE STATUS INDICATOR



MINIMAL ITEMS REMOVABLE FOR CLEANING



POLISHED INTERIOR WITH SMOOTH ROUNDED CORNERS

Consistently Outstanding Wash Results

INTENSIV wash system

- The technically advanced **INTENSIV** wash system delivers outstanding results and significantly reduces running costs

Pre-wash

- Genius X² is activated shortly after the cycle starts, removing food soil from the wash water, prior to washing

Wash

Hobart research has shown that higher wash temperatures and efficient water distribution, coupled with accurate detergent dosing optimises wash performance

ECOTHERM HEATING TECHNOLOGY

- Independently maintains wash water at 63°C even during continuous use
- Improves drying results

VECTOR WASH JETS

- The precise spray pattern ensures a substantially broader coverage, delivering a powerful searching wash action
- Detergent solution is distributed efficiently
- Masking is avoided, especially in corners

GENIUS X²

- Prior to rinsing the Genius X² is activated removing any remaining food soil
- Interlocked strainer ensures correct location and operation of filter system

X-CHANGE

- A selectable cycle which empties the wash tank completely at the end of the wash prior to rinsing - ideal when heavy soiled or greasy items need to be washed
- The machine adapts quickly and easily to varying types and degrees of soiling
- Quickly removes liquid contamination
- Provides fresh, clean wash water for the next cycle
- Eliminates the need to manually drain and refill the machine

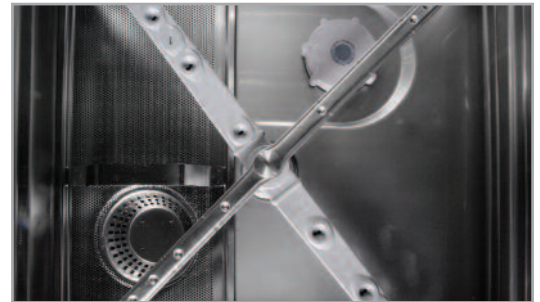

WASH & RINSE SYSTEM



VECTOR WASH JET DESIGN



GENIUS X² FILTER SYSTEM

Consistently Outstanding Wash Results



The benchmark for quality and innovation

Rinse

Ensuring constant temperature and volume of clean rinse water is vital to achieve hygienically clean results.

ACCURINSE

- Delivers precisely 2.5 litres of fresh water at a constant 82°C to guarantee perfect hygiene standards
- Accurate control of rinse water flow through the rinse booster avoids fluctuations in temperature and volume



ACCURINSE JET

FXP - VAPO-RINSE system

Unique VAPO-RINSE technology delivers outstanding results but with even lower water consumption using a two step process.

- Steam rinsing provides 100% coverage eliminating shielded areas
- Uses 36% less water and 40% less rinse aid than in conventional machines



VAPO-RINSE

FXP - Unique Cutlery Cycle

The unique cutlery cycle includes a revolutionary steam injection to give brilliant results and gleaming knives and forks



OPTISOFT FULLY AUTOMATIC WATER SOFTENING SYSTEM

Limescale is a major cause of poor wash results and machine problems. It reduces efficiency, increases running costs, causes failures and significantly affects detergent performance.

- Hobart OPTISOFT integral water softening system automatically and continuously delivers soft water
- Independent operating system eliminates interruption and extension of wash cycle times



OPTISOFT FULLY AUTOMATIC WATER SOFTENING SYSTEM

FXP - Active drying cycle

The technically advanced INTENSIV wash system is further enhanced with a revolutionary and unique drying cycle - INTENSIV4

- 3 minute drying cycle activated at end of rinse
- Drying can be selected or stopped at any time
- Removes steam from the wash chamber prior to opening the door ensuring operator safety and comfort



INTENSIV4 DRYER

Saving Money Saving The Environment

Hobart strives continuously to develop processes which reduce energy consumption and in turn reduce damaging CO2 emissions.

By utilising advanced technologies to reduce water consumption and using water more efficiently, Hobart have been able to significantly lower energy usage in the FX series.

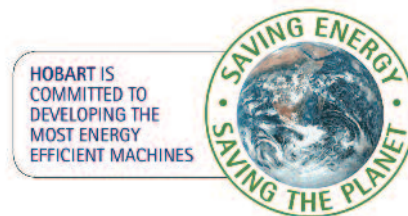

LESS WATER + LESS ENERGY = LOWER CARBON FOOTPRINT

Washing effectively

- **GENIUS X²** removes 20-40% more food soil from the wash water allowing wash tank capacity to be reduced from 13 litres to 10.8 litres (17% saving)
- Saves up to 40% on detergent usage



LOW VOLUME WASH TANK

Rinsing efficiently

- **ACCURINSE** uses just 2.5 litres of fresh water per cycle saving up to 30% on water, energy, detergent and rinse aid costs
- Advanced system delivers optimised water distribution at a constant 82°C
- **VAPO-RINSE** (FXP models) uses just 1.6 ltrs of water per cycle delivering further savings on water, energy and rinse aid costs



ADVANCED RINSE ARM DESIGN

Double racking

With a chamber height of 425mm and using Hobart stacking racks, you can halve the number of wash cycles and the time taken to wash up



DOUBLE RACKING

FX400/FX800/FXL800

- Up to 40 racks per hour with switchable electrical loadings and optional built in softener.

- FX400** Up to 20 cycles per hour with a choice of 3, 4 or 5 minute wash programmes
- FX800** Up to 40 cycles per hour with a choice of 1 1/2, 3 or 5 minute wash programmes
- FXL800** Up to 40 cycles per hour with a choice of 1 1/2, 3 or 5 minute wash programmes, oversized chamber for gastronorm pans, trays etc

Ease of operation

- **SMARTRONIC** simple button control with colour coded status sequence.
- Easy to clean wash tank and chamber with smooth, rounded corners and polished interior
- Only 6 removable items for cleaning
- Automatic self flushing drain cycle on machine shut down
- Hydraulically damped counterbalanced door
- Audible indicator advising when chemicals and detergents are running low

Consistently outstanding wash results

- **INTENSIV** - 3 stage wash process incorporates a pre-wash function which removes 20-40% more food soil
- **ECOTHERM** - Maintains wash temperature above 63°C for optimum detergent performance
- **VECTOR Wide Angle Wash Jets** - Advanced design delivers a powerful, searching wash action eliminating any "masked" areas
- **X-CHANGE** - Cycle can be activated on demand to allow the wash water to be completely replenished during the wash cycle
- Interlocked strainer ensures correct location and operation of filter system
- Wash pump soft start feature protects ware and reduces shock to components

Energy saving features

- **ACCURINSE** uses just 2.5 litres of fresh water per cycle
- **GENIUS X²** removes 20-40% more food soil from the wash water
- Wash tank capacity of just 10.8 litres



FX400/FX800



FXL800

FXP Series

FXP

- Up to 40 racks per hour with switchable electrical loadings and optional built in softener.

FXP With a choice of 1 1/2, 3 or 5 minute wash programmes

Ease of operation

- **SMARTRONIC** simple button control with unique colour coded sequence and "countdown" indication of cycle status.
- **COMPLETE** hygiene programme thoroughly cleans wash chamber and wash system
- Easy to clean wash tank and chamber with smooth, rounded corners and polished interior
- Only 6 removable items for cleaning
- **BASICLEAN** cycle for deep cleaning of heavy soiled items and for removing starch and mineral build up
- Audible indication of machine status, ie. cycle complete, low salt, low chemicals
- Full width hydraulically damped counterbalanced door



FXP

Consistently outstanding wash results

- **INTENSIV4** - 4 stage wash process featuring pre-wash, wash, rinse and a unique drying cycle
- **ECOTHERM** - Maintains wash temperature above 63°C for optimum detergent performance
- **VECTOR Wide Angle Wash Jets** - Advanced design delivers a powerful, searching wash action eliminating any "masked" areas
- **X-CHANGE** - Cycle can be activated on demand to allow the wash water to be completely replenished during the wash cycle
- **Continuous Cycle** - up to 20 minutes of washing for heavily soiled items. Can be interrupted at any time
- Interlocked strainer ensures correct location and operation of filter system
- Wash pump soft start feature protects ware and reduces shock to components



FXP

Energy saving features

- **VAPO-RINSE** uses just 1.6 ltrs of water per cycle delivering further savings of 36% on water, and 40% on rinse aid costs
- **GENIUS X²** removes 20-40% more food soil from the wash water and saves up to 40% on detergent usage
- Wash tank capacity of just 10.8 litres, saves on water and energy

Advanced FXP features

- Unique integral dryer provides rapid and effective drying of ware in just 3 minutes. Eliminates steam escape when door is opened



DRYER FAN

- Single button indicates progress of cycle
- Handle illuminates indicating machine status



CYCLE STATUS INDICATOR

- The hygiene programme using Hobart INTENSIV tablets removes starch, tannin and lime scale deposits leaving the machine clean and smelling fresh

- Integral one litre rinse aid container with convenient drawer access and low level sensor

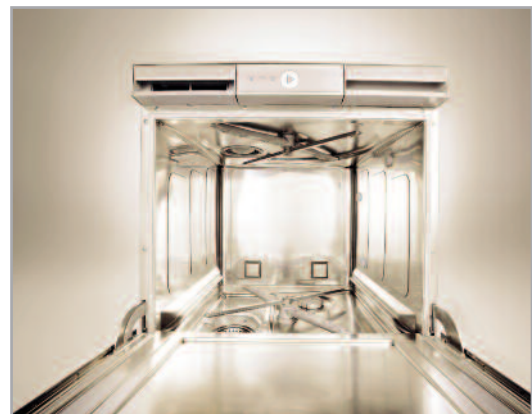

FX/FXP Series

Handling solutions

FX mounted on a base cabinet adjacent to "compact" workstation

- Allows efficient loading and unloading of racks
- Raised height improves handling and reduces strain



FX located under worktop

- Small footprint and smooth door design allows FX to be positioned and used efficiently in even the smallest areas



MODEL	FX400/FX400S	FX800/FX800S	FXL800/FXL800S	FXP/FXPS	
WATER	Water Connection	3/4" BSP	3/4" BSP	3/4" BSP	
	Water Pressure	0.6-6.0 Bar	0.6-6.0 Bar	0.6-6.0 Bar	
	Water Temperature (max)	60°C	60°C	60°C	
	Water Consumption Per Wash Tank Volume	2.5 Litres	2.5 Litres	2.5 Litres	1.6/2.5 Litres*
	Supply Hose Length	10.8 litres	10.8 litres	10.8 litres	10.8 litres
		2000mm	2000mm	2000mm	2000mm
WASTE	Drain Outlet (pumped)	28mm diameter	28mm diameter	28mm diameter	
	Drain Hose Length	2000mm	2000mm	2000mm	
ELECTRIC	Electrical Loading	5.6kW (1 x 25 Amp)	7.7kW (3 x 16 Amp)	7.7kW (3 x 16 Amp)	
	Switchable To	7.7kW (3 x 16 Amp)	5.6kW (1 x 25 Amp)	5.6kW (1 x 25 Amp)	
		2.9kW (1 x 13 Amp)	2.9kW (1 x 13 Amp)	2.9kW (1 x 13 Amp)	
	Pump Rating	0.6kW	0.6kW	0.6kW	
	2000mm	2000mm	2000mm		
OTHER	Detergent Hose Length	2500mm	2500mm	2500mm	
	Rinse Aid Hose Length	2500mm	2500mm	2500mm	
	Programme (secs)				
	P01	180	90	90	
	P02	240	180	180	
	P03	300	300	300	
	P04	-	-	-	
	Hygiene Prog (secs)	-	-	-	
	Rack Size	500 x 500mm	500 x 500mm	500 x 500mm	
	Machine Dims (wxhdx)	600 x 600 x 820mm + 80mm	600 x 600 x 820mm + 80mm	600 x 640 x 820mm + 80mm	
	Machine Weight	87 Kg	87 Kg	87 Kg	
Noise Level	63dB	63dB	63dB		
Supplied As Standard With	1 x Plate Rack 1 x Open/Cup Rack 1 x Cutlery Basket	1 x Plate Rack 1 x Open/Cup Rack 1 x Cutlery Basket	1 x Plate Rack 1 x Tray Insert 1 x Cutlery Basket	Integral Container 90 (170 with Vapo-Rinse) 180 (230 with Vapo-Rinse) 300 (conventional rinse only) Continuous 600 500 x 500mm 600 x 600 x 820mm + 80mm 87 Kg 63dB 1 x Plate Rack 1 x Open/Cup Rack 1 x Cutlery Basket	

*For shorter cycle times, FXP can be operated with a conventional 2.5ltr rinse

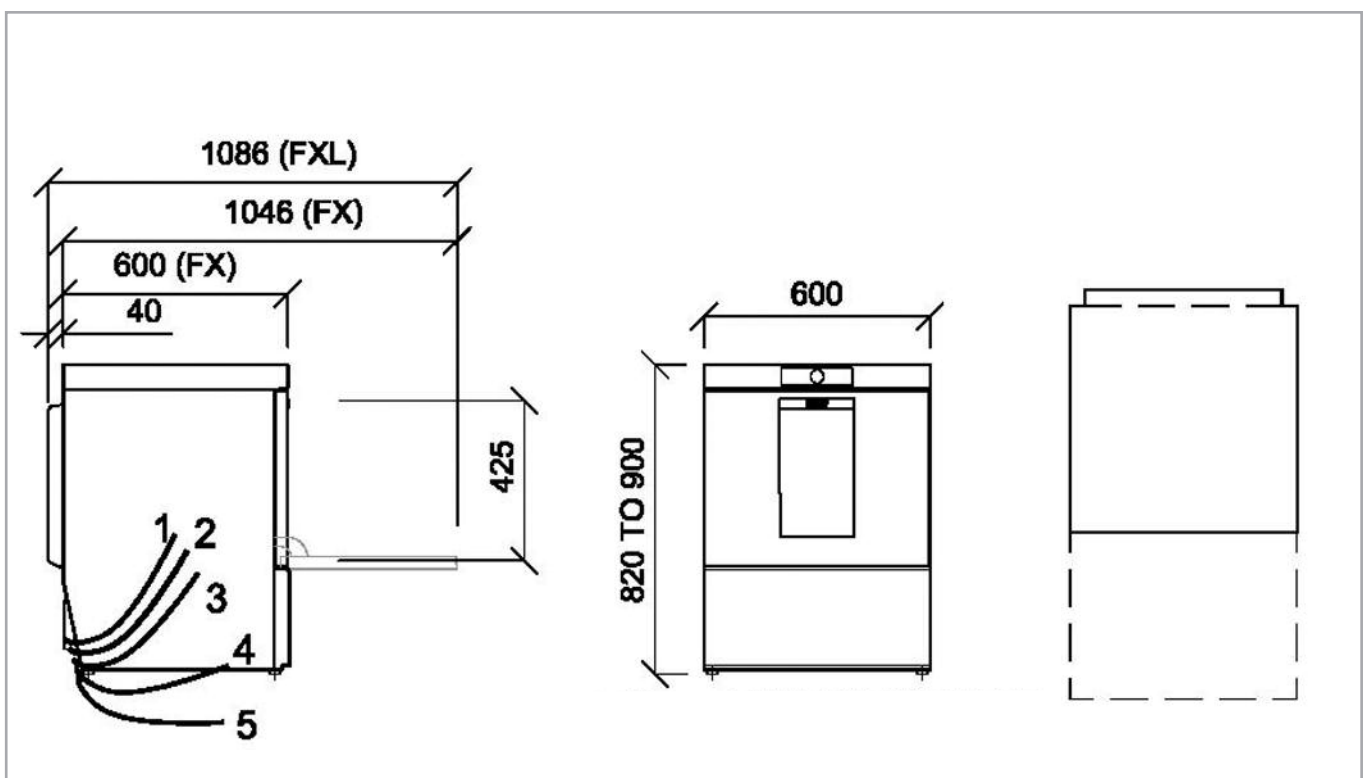

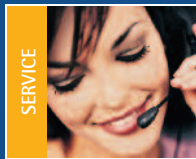
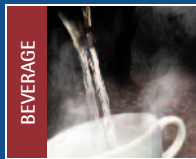

The benchmark for quality and innovation

0844 888 7777

Rol: 01246 0248

Hobart UK, 51 The Bourne, Southgate, London N14 6RT. Fax No. 020 8886 0450
www.hobartuk.com